

**MODULAR TABLE
CONCEPT**

Note that these plans are intended for the fabrication of a preliminary real-world test of the slot joint and trestle assembly.

Questions we are hoping to answer:

1. Is the slot joint practical to fabricate?
2. How stable is the assembled table base?
3. What are some practical ways to fasten parts that enable easy disassembly? (screws?)
4. Is there a need for additional components to stabilize assembly?

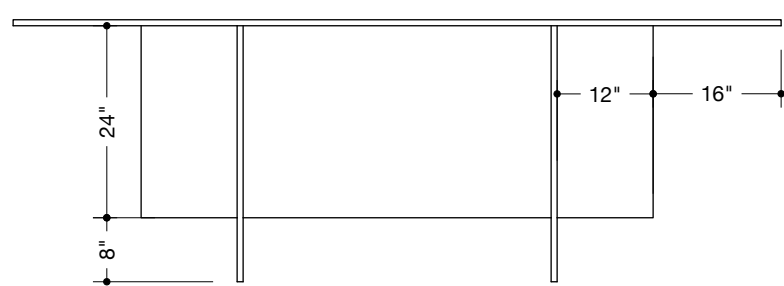
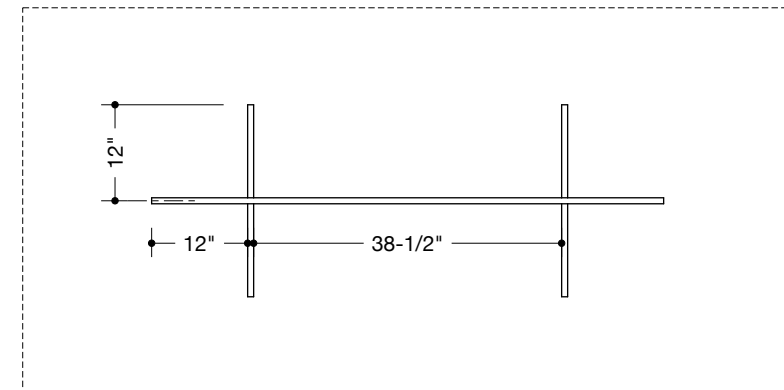
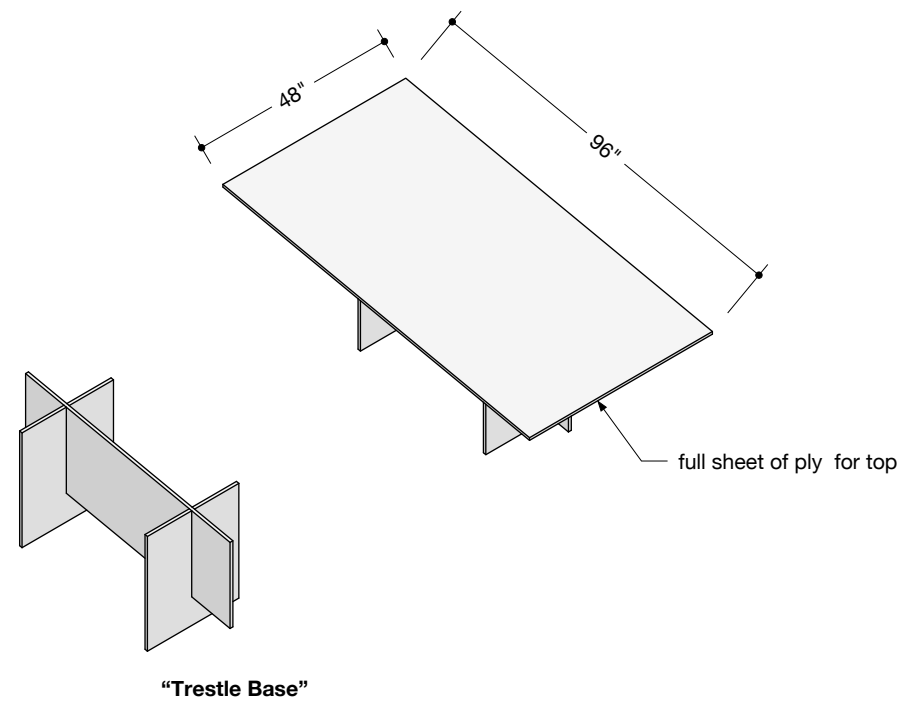
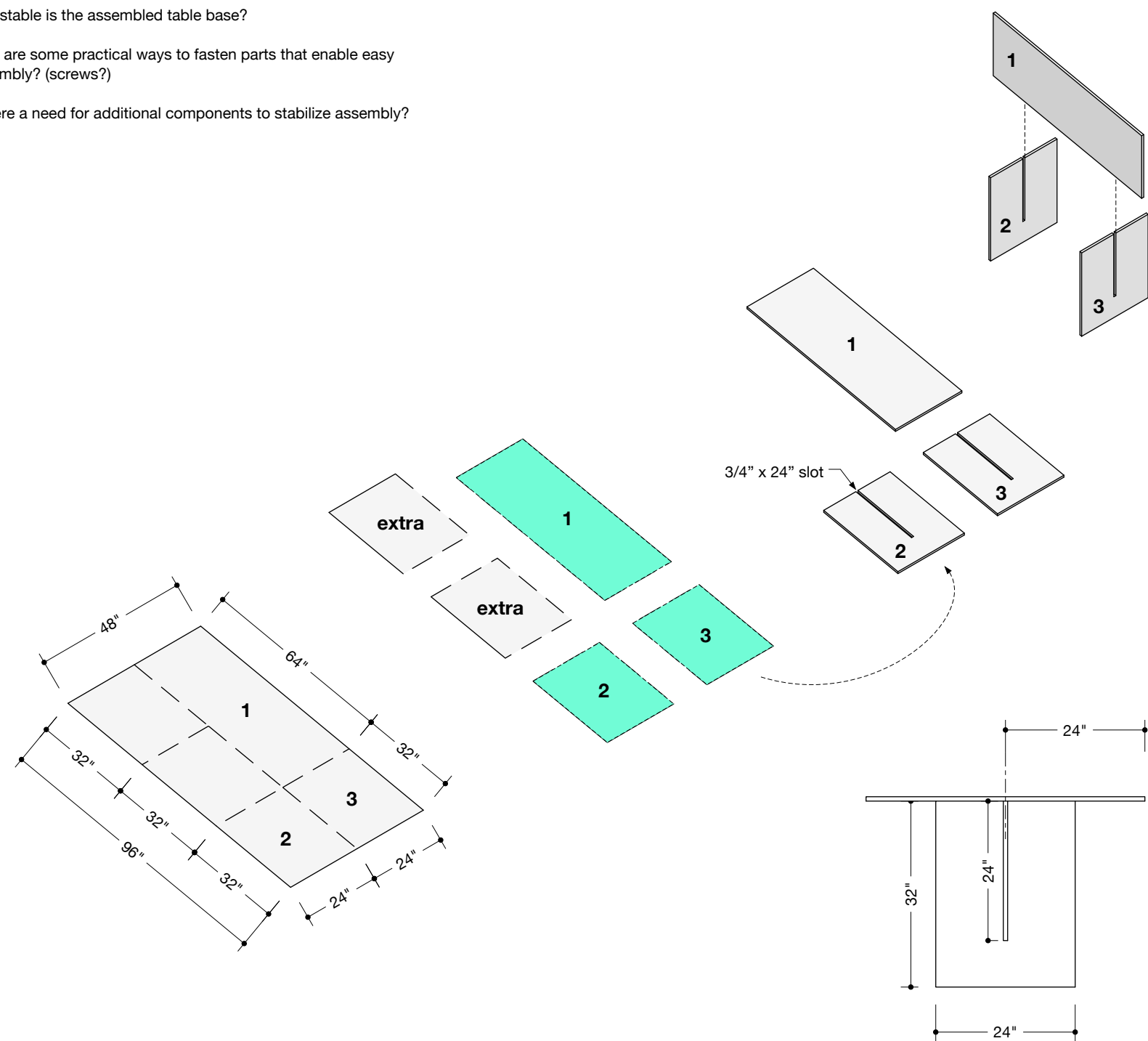

Issue		
1	REVIEW	2023.10.29

Revision		

PROTOTYPE

Project
SAGE Project
 Museum of Vancouver
 Modular Design Concepts

SCALE
AS NOTED
 DATE
29.OCT.2023
 DRAWN
ML
 CHECKED
ML